

CO₂ - RECOVERY PLANTS FOR BREWERIES

CO₂-RECOVERY PLANTS “System BUSE RGW-BRAU”

CO₂-recovery plants “**System BUSE RGW-BRAU**” are compact plants of high reliability and loading capacity, built in modular design, recovering the carbon dioxide from fermentation processes in breweries. Based on the long standing experiences of BUSE as CO₂ producer, consumer and plant manufacturer, these plants are provided with all necessary components to ensure a safe and economical production of purest carbon dioxide in breweries.

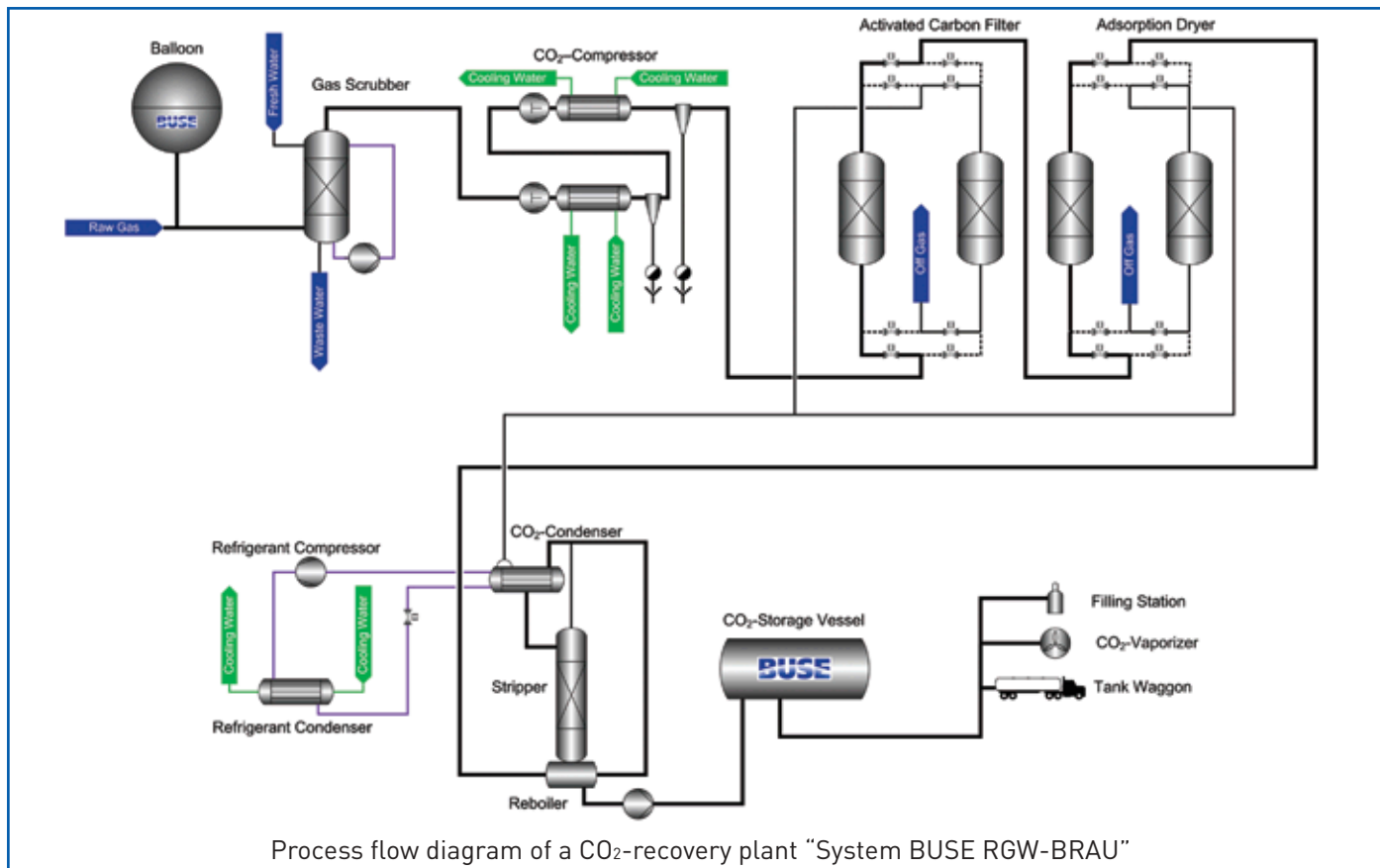

Standard CO₂-recovery plant “System BUSE RGW-BRAU0500”

Gaseous CO₂ arises during the alcoholic fermentation process in fermentation tanks, by which yeasts turn sugars into alcohol and CO₂-gas.

The recovered CO₂-gas is used in several areas of the brewery, e. g.

- for the carbonization of beer, beer-mixed drinks or soft drinks
- for pressurizing or discharging of tanks
- for the operation of bottle-and barrel filling units

PROCESS DESCRIPTION

GAS BUFFERING AND GAS SCRUBBING

The raw gas arising during fermentation, is at first led via a stainless steel foam separator in order to protect the CO₂-plant against foam penetration. For intermediate buffering of the discontinually arising CO₂, a special buffer balloon is used. In the downstream stainless steel gas scrubber the water-soluble impurities contained in the raw gas (e. g. alcohol) are highly efficiently separated by means of wash water irrigation.

CO₂-COMPRESSION, -PURIFICATION AND -DRYING

In dry-running piston compressors, the humid CO₂ is compressed absolutely free of oil to approx. 16 to 17 barg. After compression, the impurities and odours still contained in the CO₂ are removed in a regenerative purification and deodorizing unit. In an absorption dryer the residual humidity of the gas is removed.

CO₂-LIQUEFACTION AND -STORAGE

In the CO₂-liquefaction plant, the dried and purified CO₂-gas is cooled down to below -25°C and simultaneously liquefied. In our refrigeration plants we use screw or piston compressors for different refrigerants, e. g. NH₃, R507 or R404a, depending on customer's request resp. case of application. For further increase of the CO₂-purity and removal of residual O₂ (below 5 vpm) in the liquid CO₂, there is the option of connecting a stripper system downstream the CO₂-liquefier. The liquid CO₂ is finally stored in an insulated CO₂-storage tank.



Combined CO₂ purification and drying unit (left), Stainless steel gas scrubber (right)



CO₂-Stripper for highly pure CO₂

KEY BENEFITS OF BUSE CO₂-RECOVERY PLANTS

CO₂-recovery plants "System BUSE RGW-BRAU" are characterized by a high manufacturing quality and reliability. Incorporating an appropriate process control and selection of components, BUSE-plants achieve a high CO₂-yield, a high product purity and low energy consumption. In addition, the use of tested processes and standard components guarantee a favourable price/performance ratio:

The advantages at a glance:

- Highest quality of manufacturing
- Modern and reliable equipment „Made in Germany“
- Plant design to meet highest international standards
- Low production costs and high purity of final product
- Easy to operate - easy to maintain
- Quick delivery and long-term availability of original spare parts

BUSE-ENGINEERING AND PROJECT MANAGEMENT

BUSE CO₂-recovery plants are always adapted to the local site conditions. When constructing a plant, our engineering team considers the respective local area and climatic conditions and follows individual customer's requirements.



“Modern 3D-plant-engineering ensures an optimal design of the CO₂-plant even under difficult space conditions.”

Michael Schulte,
Sales Manager BUSE Gastek

In addition, BUSE-Engineering provides, besides of the construction of new equipment, engineering services in the field of plant upgrading/overhauling as well as concepts for optimization of energy efficiency and integration of the CO₂-plant-control into the process control system of the brewery.

FROM ENGINEERING RIGHT UP TO TURN-KEY PRODUCTION FACILITIES

ENGINEERING AND PLANT CONSTRUCTION

- Standard plants from 30 kg/h to 3.000 kg/h
- Special custom-tailored plants up to 15.000 kg/h
- Overhauling and upgrading of existing plants
- Turn-key supply

AFTER SALES SERVICE

- Competent service engineers
- Quick and long-lasting provision with original spare parts
- Technical support during the entire lifetime of the plant

ENGINEERING SERVICES

- Basic and detail engineering
- Process and plant optimization of existing facilities
- Design of energy saving plant concepts

WIDE RANGE OF EQUIPMENT FOR CO₂-HANDLING AND APPLICATIONS

- CO₂-storage tanks, CO₂-evaporators and CO₂-supply systems
- Gas analyzers and quality control equipment
- Dry ice production machines
- Dry ice blasting equipment for efficient and environment- friendly industrial cleaning
- Cryogenic freezing plants
- And much more...

Compact CO₂-Recovery Plant
for 30 kg/h



CO₂ IS OUR WORLD...

...and has been for over 120 years. The BUSE-position on the beverage and gas-industry is characterized by a close competence chain, that has been earned over 120 years- from a German mineral water producer to a gas producer and distributor, right up to a reputable engineering and service specialist for the gases and beverage industry.

BUSE – MORE THAN 120 YEARS OF KNOWLEDGE IN CO₂-TECHNOLOGIES

BUSE Gastek GmbH & Co.KG

Sprudelstrasse 3
D-53557 Bad Honningen / Germany
Tel. +49 2635 781 0
Fax +49 2635 781 192
E-Mail: info@buse-gastek.com
www.buse-gastek.com

ISO 9001:2008
BUREAU VERITAS
Certification

